

**SEMI-AUTOMATIC CIRCULAR SCREENING TROUGH FOR SMALL AND LARGE SOLIDS**

**MODEL: CD-MA-RAC**

**Function:**

- Removal of solids of size equal to or larger than 6 mm.

**Characteristics:**

- Manufactured by Salher, Model CD-MA-RAC.
- Trough made of Fiberglass Reinforced Polyester (FGRP) with orthophthalic resin.
- Perforated stainless steel grating for selection of large particles of 30 mm.
- Perforated stainless steel grating for selection of small particles of 6 mm.
- Manually operated treatment system for large solids and automatic system for small solids.
- PVC inlet and outlet pipes.
- Stainless steel screening basket with a perforated plate at the bottom for waste dewatering.
- Stainless steel scraper to remove solid residues.

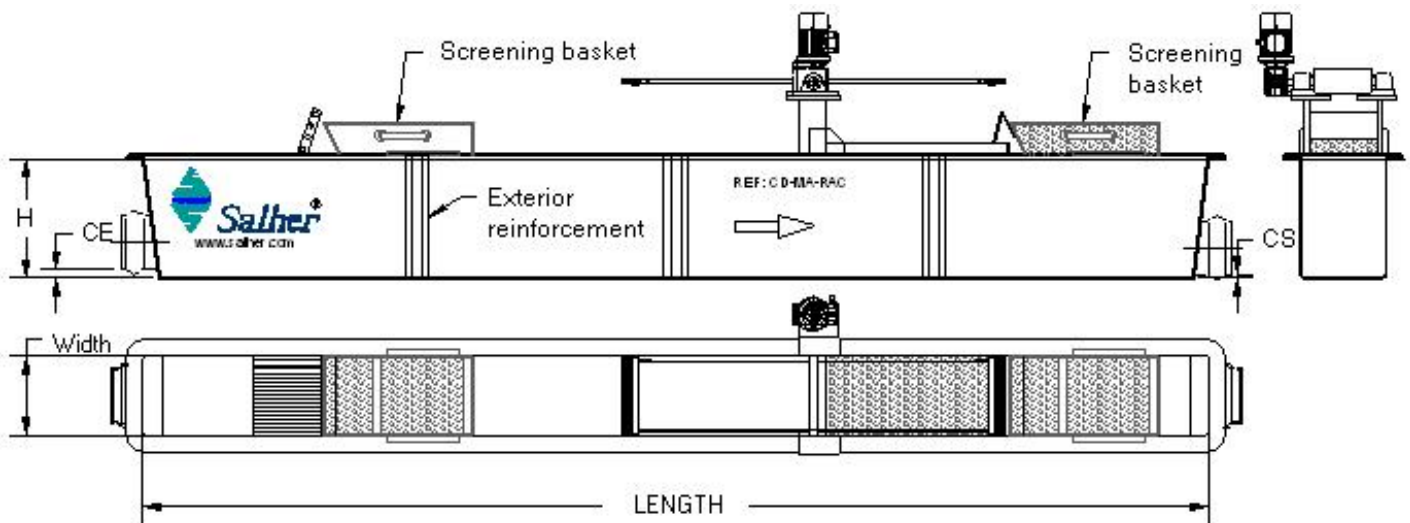

W [mm]	H [mm]	CANAL LENGTH [mm]	INLET CE [mm]	OUTLET CS [mm]	GRATING-LARGE SCREENINGS [mm]	GRATING-SMALL SCREENINGS [mm]	PIPE Ø [mm]
200	360	3.000	50	40	200x380	200x380	125
400	400	3.000	50	40	400x380	400x380	315

INNER SIZE IN MM.

OTHER PIPES DIAMETERS AVAILABLE AT REQUEST.