

**SETTLING-DIGESTION SYSTEM: VERTICAL SEPTIC TANK <5EP**  
**MODEL: CVC-FS**

**Function:**

- Removes suspended solids (SS or SM).

**Characteristics:**

- Manufactured by Salher, Model CVC-FS.
- Made of Fiberglass Reinforced Polyester (FGRP) with orthophthalic resin.
- Suspended solids removal efficiency: 65-70%.
- Organic matter removal efficiency: 30-35% BOD5.
- Settling, digestion and floating particles separation chamber.
- PVC inlet and outlet pipes.
- Access for cleaning through the manhole with upper cover made of Fiberglass Reinforced Polyester. For authorized operating staff. (Option: Upper cover in cast-iron or to screw-down).
- Connection pipe located in the manhole to install the air vent (or possibility to install it in any other place).

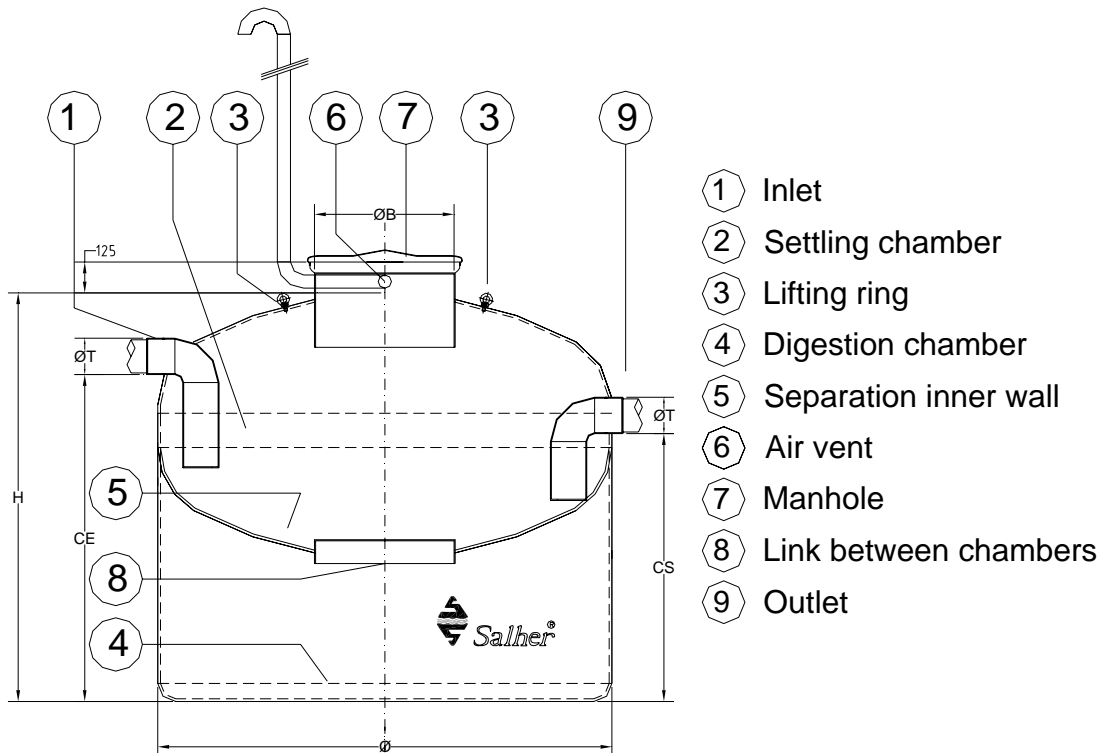

POP/ EQUIV	CAPACITY [liters]	Ø [mm]	H [mm]	MANHOLE Ø [mm]	PIPE Ø [mm]
2	500	1.000	750	400	125
5	1.000	1.000	1.320	400	125