

OPEN SETTLING TANK
MODEL: CVA – DC - TC

Function:

- Remove suspended solids.

Characteristics:

- Manufactured by Salher, Model CVA - DC – TC.
- Made of Fiberglass Reinforced Polyester (FGRP) with orthophthalic resin.
- Suspended solids removal efficiency: 65 – 70% SS.
- Organic matter removal efficiency: 30 – 35% BOD5.
- Geometric form: Conical.
- Central supply chamber and Thompson canal.
- PVC inlet and outlet pipes.
- Connection pipe located on the manhole to install the air vent (or possibility to install it in any other place).

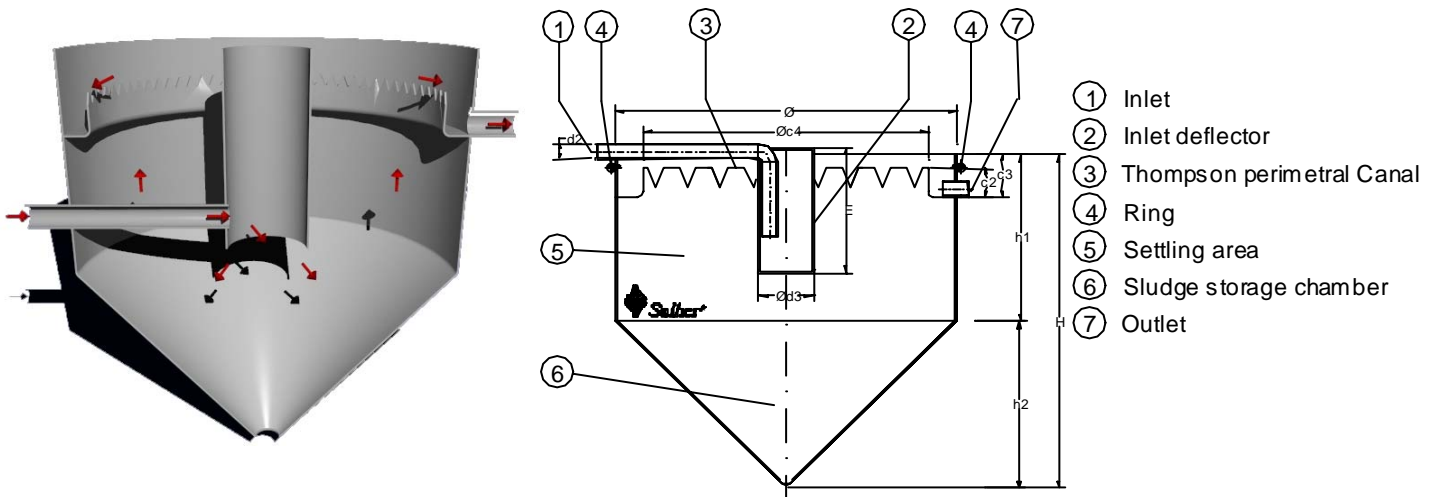

Main Cylinder					Partial Heights			CANAL				CAPACITY IN LITERS
φD	φd1	φd2	φd3	E	h1	h2	H	c1	c2	c3	c4	
1.000	75	75	300	700	800	500	1.300	100	150	300	750	750
1.200	75	75	300	700	800	600	1.400	100	150	300	1.000	1.130
1.400	90	90	300	700	800	700	1.500	100	150	300	1.200	1.590
1.700	90	90	400	900	1.000	850	1.850	150	200	300	1.400	2.910
2.000	110	110	500	900	1.000	1.000	2.000	150	200	300	1.700	4.190
2.500	160	160	620	1.000	1.200	1.250	2.450	250	250	350	2.000	7.930
3.000	160	160	690	1.200	1.400	1.500	2.900	250	250	350	2.500	13.420
3.500	200	200	750	1.400	1.600	1.750	3.350	250	300	400	3.000	21.000
4.000	200	200	1.000	1.600	1.800	2.000	3.800	250	300	400	3.500	30.980