

*This document is subject to intellectual property right and client shall not copy, amend or hand it on to third parties except if for personal use.*

## LOW CHARGE ACTIVATED-SLUDGE TREATMENT PLANT WITH CONICAL SETTLING TANK, BLOWER, FINE BUBBLES DIFFUSERS AND SLUDGE RECIRCULATION SYSTEM

MODEL: CVC-OXIDEP-TC

### Function:

- Organic matter removal (BOD5).

### Characteristics:

- Manufactured by Salher, Model CVC-OXIDEP-TC.
- Made of Fiberglass Reinforced Polyester (FRP) with orthophthalic resin.
- Organic matter removal efficiency (BOD5)  $\geq$  90%.
- Oxygen transfer and mixed liquor homogenization through blower and fine bubbles diffusers in EPDM.
- Activated-sludge recirculation system.
- Conical settling tank with central supply and a Thompson canal.
- PVC inlet and outlet pipes.
- Access via manhole with upper cover in Fiberglass Reinforced Polyester (option: Upper cover in cast-iron or to screw-down).
- Possibility to locate the air vent on the manhole (or in any other place).

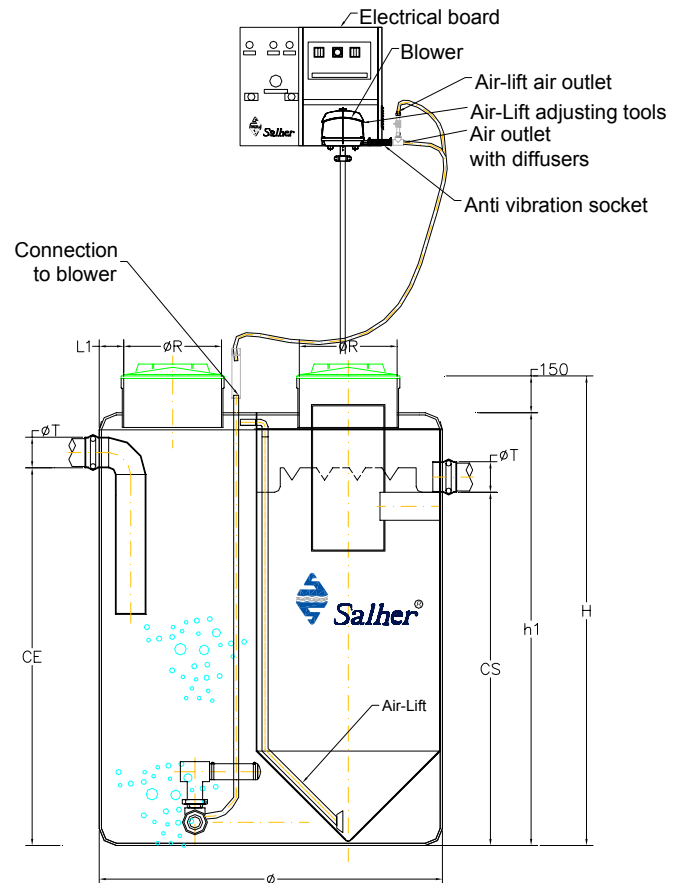

PE	Capacity [liters]	Ø [mm]	H [mm]	INLET [mm]	OUTLET [mm]	PIPE Ø [mm]	Blower (W)	Noise Level [dB]	Diffusers
≤10	3.100	1.400	2.175	1.800	1.700	125	80	39	2DBF500
20	6.300	2.000	2.175	1.800	1.700	125	138	44	2DBF500
30	9.600	2.250	2.575	2.200	2.100	125	200	45	3DBF500
40	11.900	2.500	2.575	2.200	2.100	125	2 x 138	55	4DBF500
50	13.800	2.500	2.975	2.600	2.500	125	2 x 200	60	4DBF500

**ELECTRICAL BOARD FOR CVC-OXIDEP-TC**
**Characteristics:**

- Equipment box sized 500 x 400 x 300 mm with compartment for the blower.
- Indicator light.
- On-off-Automatic switch.
- Thermal protection and timer to control the blower.
- Air injection for the blower.
- Air outlet with regulating valve for Air-Lift and anti vibration hose.



PANEL BOARD 50 HZ 220V
PANEL BOARD 60 HZ 220V
PANEL BOARD 50HZ 120 V (WITH 120-220V TRANSFORMER)