

CLASS II HYDROCARBON SEPARATOR, 3 SEPARATION CHAMBERS WITH AUTOMATIC OBTURATOR AND OIL FILTER

MODEL: CHC-SHC-3-FO; CHC-SHC-3-F; CHC-SHC-3-O

Function:

- Mineral oil, grease and hydrocarbon separation by density difference it does not separate emulsified oil and hydrocarbon.

NOTICE: For organic oil and grease removal (from vegetables and animals) please refers to Grease separator Chamber.

Characteristics:

- Manufactured by Salher, Model CHC-SHC-3-FO (with filter and obturator); CHC-SHC-3-F (with filter); CHC-SHC-3-O (with obturator) Class II, outlet smaller than 10 ppm.
- Designed according to DIN 1999 and UNE 858 Standards.
- Made of Fiberglass Reinforced Polyester (FGRP) with orthophthalic resin.
- Oil and hydrocarbon separation and solids settling chamber.
- Separated oil and hydrocarbon gather on the surface of water.
- Oil filter and automatic floating obturator with self-locking system.
- Oil removal through upper manholes.
- PVC inlet and outlet pipes. Manhole with air vent to install the ventilation pipe.
- In option: Oil and hydrocarbon detection alarm.

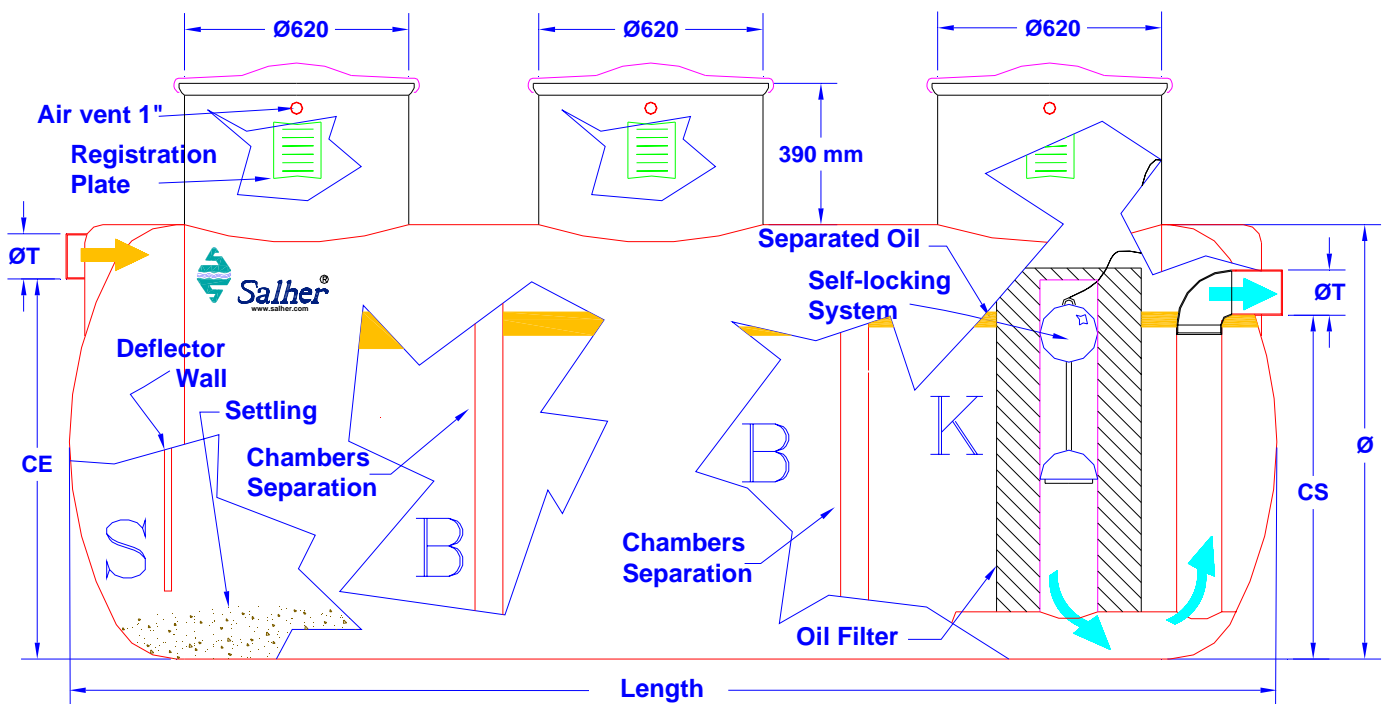

FLOW [mm]	CAPACITY [Liters]	Ø [mm]	LENGTH [mm]	PIPE Ø [mm]	MANHOLE Ø [mm]
5	3.200	1.200	3.340	125	620
7	4.500	1.400	3.200	160	620
10	7.500	1.400	5.150	160	620
15	11.000	1.700	5.180	160	620
20	18.000	2.000	6.120	200	620
25	22.500	2.000	7.850	250	620

FLOW (L/S) CAPACITY (L) SIZE (MM) FOR LARGER FLOW PLEASE CONSULT US