

**CAST IRON COVER CLASS D 400**  
**BREAKING LOAD > 400 kN**  
**MODEL: TAPA-D40**

**Characteristics:**

- Manufactured according to the ISO 1083 (1987) Standard and pursuant to the D 400 class of the UNE- EN-124 (1995) standard. It is inscribed "Wastewater Treatment Plant".

**Description:**

- Circular cover with a lock protected with a plastic joint. It is equipped with noise-reducing and anti-slip polythene joint.
- The frame has cells to optimize this installation and 4 small holes to clamp it to the floor if necessary.

**Installation Area**

- On the pavement, including pedestrian streets, verges, and parking areas for any type of vehicles. (Group 4 UNE-EN-124 Standard of 1995).

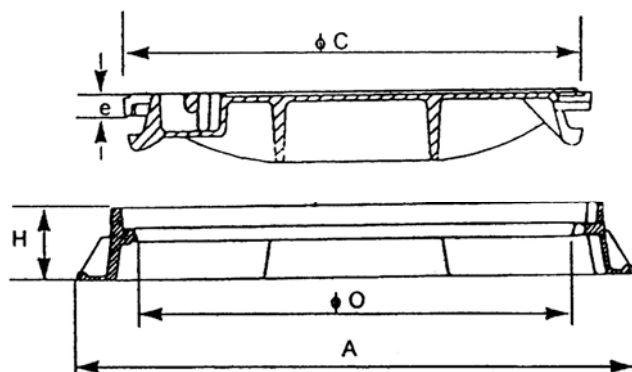

DIMENSIONS (mm)					WEIGHT (Kg)		
A	C	O	H	e	Frame	Cover	Total
850	650	600	100	27	29	36	65