

ELECTRO-MECHANICAL SKIMMER**MODEL: SK****Function:**

- Mineral oil and hydrocarbon collection in water or in aqueous solutions.

Characteristics:

- Made of AISI 304 Stainless Steel.
- Oil belt designed for use in extreme conditions.
- Cast-iron security chain to avoid the loss of the skimmer if the band breaks.
- Anti spatter protection body in AISI 304 stainless steel.
- It can be used as a pretreatment, before the filtration or in combination with a coalescence system.
- Compact, robust and handy.
- Programmer and explosion-proof protection in option.

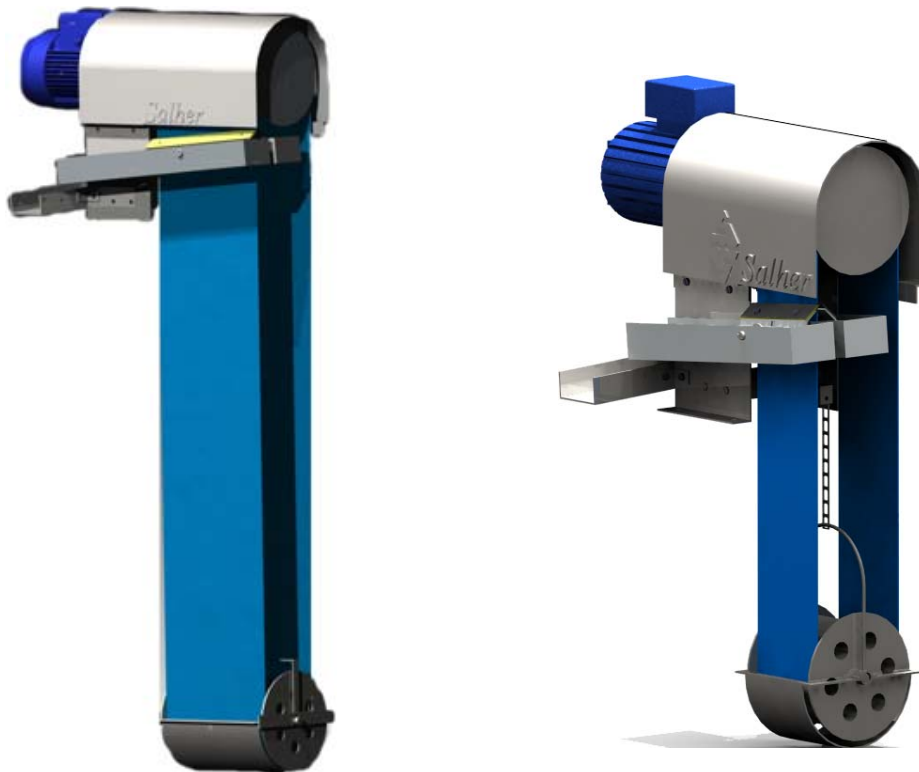

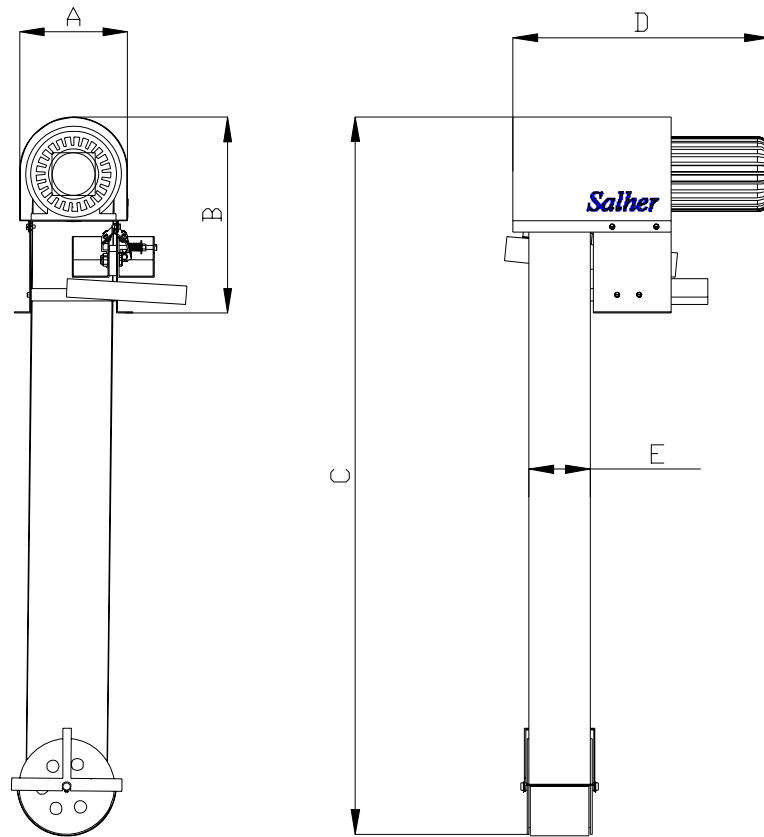

MODEL	A [mm]	B [mm]	C [mm]	D [mm]	E [mm]	Q [l/s]
SK - 100	176	320	TO DETERMINE	420	100	50
SK - 150	176	320	TO DETERMINE	470	150	76
SK - 200	176	320	TO DETERMINE	520	200	100

* All measures are given in mm.

** The flows are indicative and depend on the products viscosity and the working depth.