

**CAST IRON COVER CLASS D 400**  
**HARMFUL LOADING >400 kN**  
 MODEL: TAPA: D40



**Characteristics:**

Manufactured according to ISO 1083 (1987) Standard according to D 400 Class of UNE-EN-124 (1995) Standard, with label: "Wastewater Treatment Plant".

**Description:**

Round cover along with interlock, protected with plastic stopper, and covered with anti-slip and noise deadening layer.

**Application**

Designed to be installed on pedestrian streets, roads and parking areas for any type of vehicles.  
 (Group 4 of UNE-EN-124- Standard from 1995).

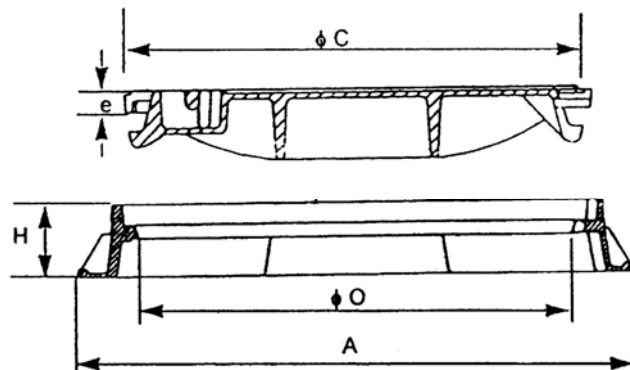

DIMENSIONS [mm]					WEIGHT [Kg]		
A	C	O	H	e	FRAME	COVER	Total
850	650	600	100	27	29	36	65