

## FINE BUBBLES DIFFUSERS

MODEL: DBF

### Characteristics:

- Diffusers are setting with two PVC pipelines, connected by a T-shaped part. Around pipelines a membrane is installed that distributes air inside a tank.
- Micro-openings of membrane operate like a valve, which opens to let air pass and close when water flows. Membrane provides air bubbles of 0.5 to 1.0 mm diameter. Efficiency of process may be enhanced due to the following facts:
  - larger oxygen exchange surface
  - longer immersing of bubble into water

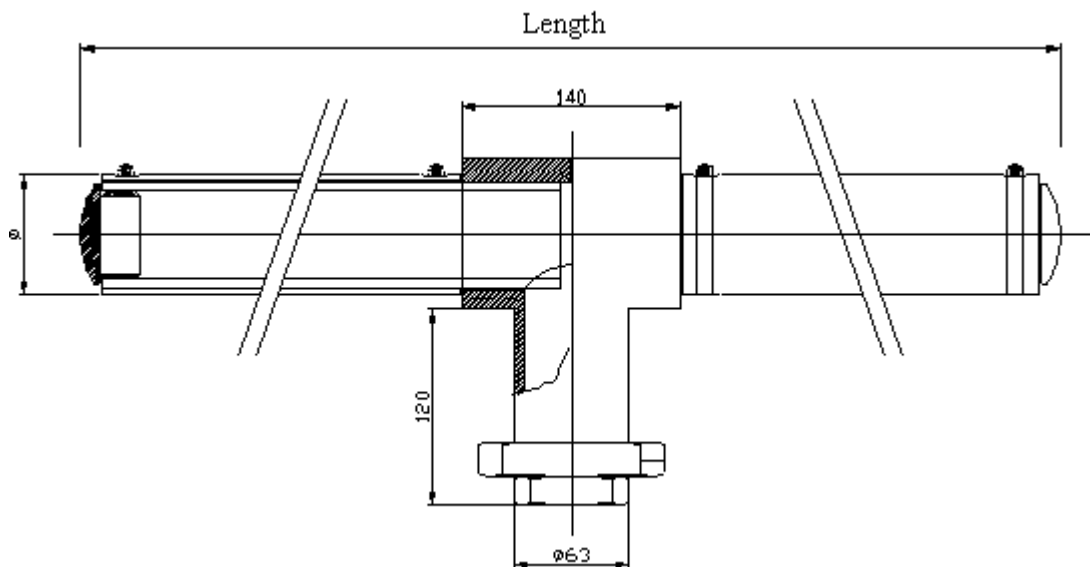

MODELS	LENGTH
DBF1000	1.140
DFF500	640

SIZE IN MILLIMETERS